

Installation to a Solid Wall

1. Determine the route for the hot and cold supply pipework.
2. Determine the desired position of the mixer valve.
Note! To enable sufficient clearance the valve must be a minimum 1.1 m from the ceiling.
3. Cut away the brick work to the required depth.
4. Install the supply pipework using the Pipe Spacer to secure as necessary, the pipework should extend a minimum of 50 mm from the finished wall surface. Use the Tiling Guide to ensure the pipe centres are correct (50 mm) **Note!** Ensure that the pipework protruding from the wall is level, in line and rigidly secured. Plastic piping must not be used to connect the valve to the supply pipework.

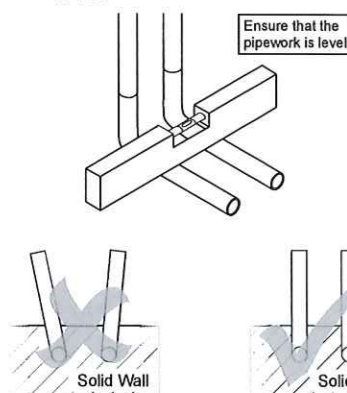

5. Finish the wall e.g. Tiles, making sure to tile around the tile guide.
6. Follow steps 9 - 17 from section "Installation to a Panelled / Partition Wall".
7. Turn on the water supplies and check for leaks.
8. The installation of the mixer valve to a solid wall is now complete.

FITTINGS

Please refer to the Fittings Installation and User Guide.

COMMISSIONING

Before using the shower the maximum temperature must be checked to make sure that it is at a safe level. It has been preset to approximately 41°C at the factory but due to variations in site conditions the maximum temperature may need adjustment. For Type 2 installations the maximum blend temperature is determined by the application, refer to the TMV2 Requirements Manual. **Note!** Make sure that the hot water temperature is at least 55°C and that there is sufficient supply.

Turn on the mixer to the maximum temperature and maximum flow and allow the temperature to stabilise. If the temperature is too hot or too cold adjust as follows:

- **Single Control models** - Pull the control from the body then unscrew the hub retaining screw with a 2.5 mm hexagonal key. **Note!** Do not remove the hub.
 - **Dual Control models** - Carefully remove the concealing cap from the control.
1. Insert the 2.5 mm hexagonal key into the centre of the spindle and engage with the recessed temperature adjusting screw.
 2. Rotate the hexagonal key until the required maximum temperature is obtained at the shower. Anticlockwise to increase the temperature, or clockwise to decrease the temperature (¼ turn = approximately 1°C).
 3. Once the desired maximum blend temperature has been achieved turn off the mixer by rotating either the hub or flow control (depending on model) fully clockwise. **Note!** Do not remove the hub.
 4. Refit the hub retaining screw then refit the control (Single Control models).
 5. Refit the concealing cap (Dual Control models).
 6. Check that the shower temperature is correct.

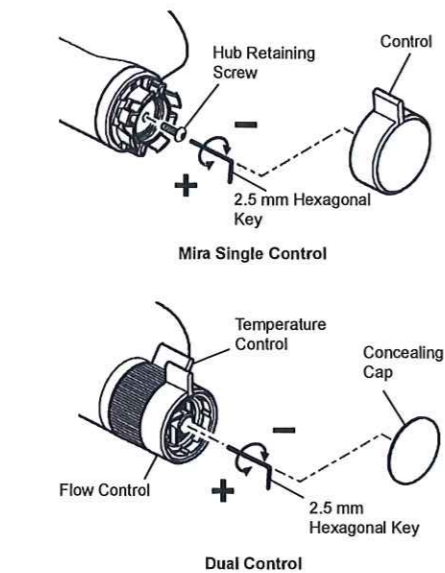

OPERATION

Having completed the installation, make sure the user is familiar with the operation of the shower.

Single Control mixers use a single sequential control for on/off and temperature control.

The control operates anti-clockwise in the following sequence:

- Off
- Cold
- Hot (Maximum Preset Temperature)

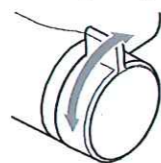

Dual Control mixers have separate controls for on/off and temperature.

The controls operate in the following sequence:

- | | |
|-------------------------------|-------------------------------|
| Flow Control (anti-clockwise) | Temp Control (anti-clockwise) |
| • Off | • Full Hot |
| • Reduced Flow Override * | • 41° |
| • Full Flow | • Full Cold |

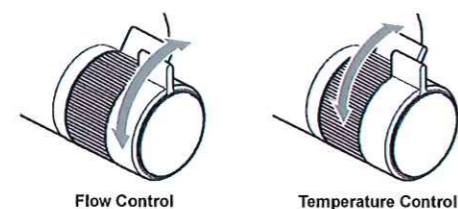

* Reduced Flow Override - reduces water flow by up to 30% (dependent on inlet pressures) and can be overridden by increasing flow to full.

FAULT DIAGNOSIS

Symptom:

- Only hot or cold water from the mixer outlet.
- Outlet temperature too hot / too cold.

Cause Rectification:

- Inlets reversed (hot supply to cold supply). Installation error, supply pipework requires rework.
- No hot water reaching mixer.
- Check the filters for any blockage refer to section 'USER MAINTENANCE'.
- Installation conditions outside operating parameters, refer to sections: 'SPECIFICATION' and 'COMMISSIONING'.
- If the temperature is too cold and you have a combination type boiler it may not be producing sufficiently hot water at desired flow rate (refer to 'SPECIFICATION'). Make sure flow regulator is fitted. For more information contact Mira Showers or visit the website..

Symptom:

- Fluctuating or reduced flow rate.

Cause Rectification:

- Check the showerhead, hose and filters for any blockage.
- Make sure that the maintained inlet pressures are nominally balanced and sufficient, refer to section: 'SPECIFICATION'.
- Make sure that the inlet temperature differentials are sufficient, refer to section: 'SPECIFICATION'.
- Air lock or partial blockage in the pipework.
- Low flow causing combination boiler to cycle. Operate shower at full flow.
- Remove 12 L/min flow regulator if used with a gravity fed system, see Fittings Installation and User Guide.

Symptom:

- Water leaking from the showerhead.

Cause Rectification:

- Normal for a short period after shut off.
- Check that the pressures are not in excess of the specifications for the product.
- Renew the cartridge.

USER MAINTENANCE

In-service Tests

The principal means for determining the continuing satisfactory performance of the mixing valve is the in-service test, refer to the TMV2 Requirements Manual.

Frequency of In-service Tests - Commercial (non-domestic installations)

Check for correct blend setting every 6 months.

Filter Replacement

1. Isolate the water supplies.
2. Open the flow control to relieve water pressure and to drain any residual water.
3. Unscrew the shower hose or rigid riser from the mixer outlet.
4. Remove mixer valve in reverse order of install. See section "INSTALLATION"
5. Pull the mixer from the wall.
6. The filters are retained in the mixer valve, remove and inspect for debris blockage. Clean the filters under a jet of water to remove any lodged particles.
7. Refit or replace the filters and reassemble in reverse order.
8. Restore the water supplies and check for leaks.

Lubricants

Silicone based lubricants must only be used on the rubber seals. **Caution!** Oil based or other lubricant types may cause rapid deterioration of seals.

Cleaning

The chrome plated parts should be cleaned using a mild washing up detergent or soap solution, rinsed and then wiped dry with a soft cloth.

Warning! Many household cleaners contain abrasive and chemical substances, and should not be used for cleaning plated or plastic fittings.

Do not use descalants on this product.

SPARE PARTS

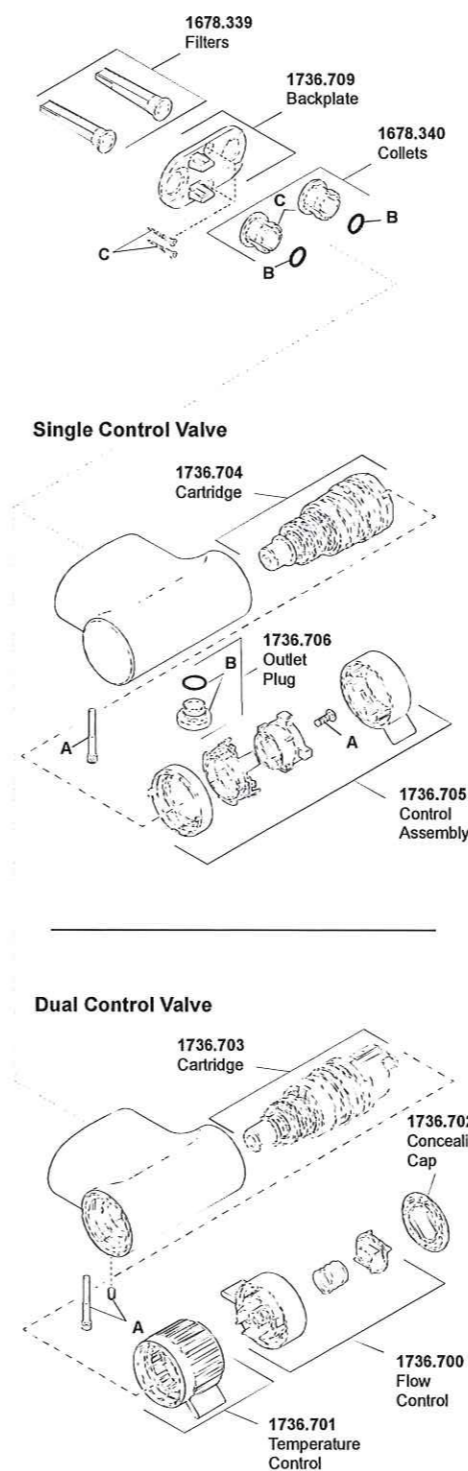

1736.707 Screw Pack - Components Identified 'A'
1736.708 Seal Pack - Components Identified 'B'
1736.717 Component Pack - Components Identified 'C'

CUSTOMER SERVICE

Guarantee

Your product has the benefit of our manufacturer's guarantee which starts from the date of purchase. To activate this guarantee, please return your completed registration card, visit our website or free phone 0800 0731248 within 30 days of purchase (UK only).

Within the guarantee period we will resolve defects in materials or workmanship, free of charge, by repairing or replacing parts or product as we may choose.

This guarantee is in addition to your statutory rights and is subject to the following conditions:

- The guarantee applies solely to the original installation under normal use and to the original purchaser only. The product must be installed and maintained in accordance with the instructions given in this user guide.
- Servicing must only be undertaken by us or our appointed representative. **Note!** If a service visit is required the product must be fully installed and connected to services.
- Repair under this guarantee does not extend the original expiry date. The guarantee on any replacement parts or product ends at the original expiry date.
- For shower fittings or consumable items we reserve the right to supply replacement parts only.

The guarantee does not cover:

- Call out charges for non product faults (such as damage or performance issues arising from incorrect installation, improper use, inappropriate cleaning, lack of maintenance, build up of limescale, frost damage, corrosion, system debris or blocked filters) or where no fault has been found with the product.
- Water or electrical supply, waste and isolation issues.
- Compensation for loss of use of the product or consequential loss of any kind.
- Damage or defects caused if the product is repaired or modified by persons not authorised by us or our appointed representative.
- Routine maintenance or replacement parts to comply with the requirements of the TMV 2 or TMV 3 healthcare schemes.
- Accidental or wilful damage.
- Products purchased ex-showroom display.

What to do if something goes wrong

If your product does not work correctly refer to this manual for fault diagnosis and check that it is installed and commissioned in accordance with our instructions.

If this does not resolve the issue, contact us for help and advice.

Extended Guarantees

A selection of protection plans are available that enable you to cover repair bills (excludes Eire). Ring 01922 471763 for more details.

Helpdesk Service - Ring our Customer Services Team for product advice, to purchase spare parts or accessories or to set up service visit. You can contact us via phone or e-mail, details below. Please provide your model name, power rating (if applicable) and date of purchase.

Mira Showers Website (www.mirashowers.co.uk) Visit our website to register your guarantee, download user guides, diagnose faults, purchase our full range of accessories and popular spares, or request a service visit.

Spares and Accessories - We hold the largest stocks of genuine Mira spares and accessories. Contact us for a price or visit our website to purchase items from our accessory range and popular spares.

Service/Repairs - No one knows our products better than our nationwide team of Service Technicians. We can carry out service or repair work to your product both during and after the guarantee period. Ask about our fixed price service repairs.

To Contact Us

0844 571 5000

Fax: 01 242 282595

E-mail: Visit www.mirashowers.co.uk/contactus

Mira Customer Services Dept, Cromwell Road, Cheltenham, Gloucestershire, GL52 5EP

To Contact Us: Eire Only

01 531 9337

E-mail: CustomerServiceEire@mirashowers.com

Mira is a registered trade mark of Kohler Mira Limited. The company reserves the right to alter product specifications without notice.



1199918-W2-D (B96 A,C,D) (1736) © Kohler Mira Limited, May 2013

**Mira Agile and Mira Pronta
Thermostatic Mixers**

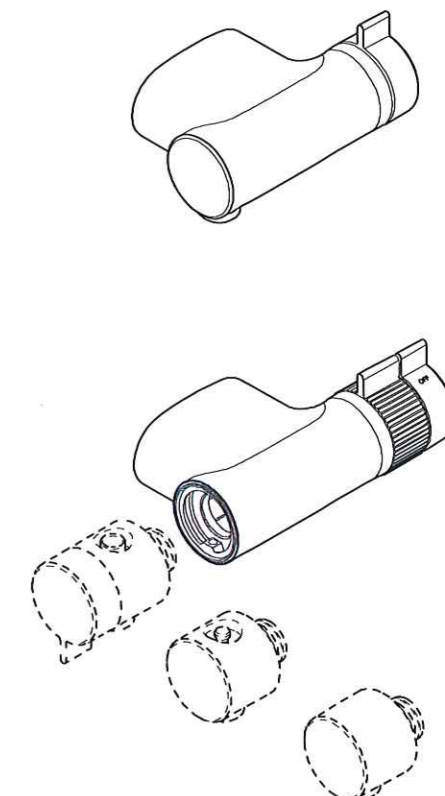

These instructions must be left with the user

Installation and User Guide

Showering perfection



INTRODUCTION

Thank you for purchasing a quality Mira product. To enjoy the full potential of your new product, please take time to read this guide thoroughly, having done so, keep it handy for future reference.

The Mira Agile and Mira Pronta are thermostatic mixing valves. Thermostatic mixers incorporate a wax capsule temperature sensing unit, which provides an almost immediate response to changes in pressures or temperature of the incoming water supplies, to maintain the selected temperature. An adjustable maximum temperature stop is provided which limits the temperature to a safe level. Inlet filters are fitted to protect the thermostatic cartridge.

Type 2 Valves

For Type 2 Valves refer to the TMV2 Requirements Manual.

This product has been certified as a Type 2 valve under the BUILDCERT TMV2 scheme. It also complies with the Water Supply (water fittings) Regulations 1999.

The approved designations for Type 2 Valves are as follows:

Models	Designation
Mira Agile	HP-S, HP-SE, LP-S
Mira Pronta	

Guarantee

For domestic installations, Mira Showers guarantee the products listed in this guide against any defect in materials or workmanship for a period of five years from the date of purchase (showers fittings for one year).

For non-domestic installations, Mira Showers guarantee the products listed in this guide against any defect in materials or workmanship for a period of one year from the date of purchase. For terms and conditions refer to the back cover of this guide.

Recommended Usage

Application	Valve with Fittings
Domestic	✓
Heavy Commercial	✗
Light Commercial	✓
Healthcare	✗

Patents and Design Registration

Design Registration:	001312649-0001 to 001312649-0022
Patents:	GB: 2 422 886 Euro: 1 672 257 DE, FR, GB, IT, NL, SE USA: 8 167 215
Patent Application:	Euro: 07015846.4 USA: US-2010-0219255-A1 PCT: GB 2011 / 050810 GB 2012 / 051147

SAFETY WARNINGS

WARNING - This product can deliver scalding temperatures if not installed, operated or maintained in accordance with the instructions, warnings and cautions contained in this guide.

The function of a thermostatic mixing valve is to deliver water consistently at a safe temperature. In keeping with every other mechanism, it cannot be considered as functionally infallible and as such, cannot totally replace a supervisors vigilance where that is necessary. Provided it is installed, commissioned and maintained within manufacturers recommendations, the risk of failure, if not eliminated, is reduced to the minimum achievable.

Mira thermostatic mixers are precision engineered and should give continued safe and controlled performance, provided:

- They are installed, commissioned, operated and maintained in accordance with the manufacturer's recommendations.
- Periodic attention is given, when necessary, to maintain the product in good functional order.
- Type 2 Valves are only used for applications covered by their approved designations, refer to the TMV2 Requirements Manual.

Caution!

- DO NOT install the product in a position in which service access is restricted.
- Read all of these instructions. Retain this guide for later use.
- Installation must be carried out in accordance with these instructions, and must be conducted by designated, qualified and competent personnel.

- Pass on this guide in the event of change of ownership of the installation site.
- Follow all warnings, cautions and instructions contained in this guide.
- Make sure that you fully understand how to operate this shower before use, read all operating instructions and retain this guide for future reference.
- This product is not intended for use by persons (including children) with reduced physical, sensory or mental capabilities, or lack of experience and knowledge, unless they have been given supervision or instruction concerning the use of the product by a person responsible for their safety.
- Anyone who may have difficulty understanding or operating the controls of any shower should be attended whilst showering. Particular consideration should be given to the young, the elderly, the infirm or anyone inexperienced in the correct operation of the controls.
- Children should be supervised to ensure that they do not play with the product.
- DO NOT perform any unspecified modifications to the shower or its accessories. When servicing only use genuine Kohler Mira replacement parts.
- Only Mira recommended outlet fittings should be used.
- DO NOT operate the temperature control rapidly, allow 10 – 15 seconds for the temperature to stabilise before use.
- Care is required when adjusting flow or temperature, make sure that the temperature has stabilised.
- Care is required if the product is turned off and back on during showering as this may result in unstable temperature. Ensure temperature has stabilised before re-using product.
- Sunburn or skin conditions can increase your sensitivity to hot water. Make sure that you set the shower to a cooler temperature.
- DO NOT fit the product where it may be exposed to freezing conditions. DO NOT operate if the appliance is frozen, allow the appliance to thaw and check for leaks before using.
- Insulate any pipework that could be exposed to freezing conditions.
- The water supplies to this product must be isolated if the product is not to be used for a long period of time. If the product or pipework is at risk of freezing during this period they should also be drained of water.
- When this product has reached the end of its serviceable life, it should be disposed of in a safe manner, in accordance with current local authority recycling, or waste disposal policy.
- If you experience any difficulty with the installation of your new shower, then please refer to "Fault Diagnosis", before contacting Kohler Mira Limited. Our telephone and fax numbers can be found on the back cover of this guide.

PACK CONTENTS

- Tick the appropriate boxes to familiarise yourself with the part names and to confirm that the parts are included.

- 1 x Thermostatic Mixing Valve

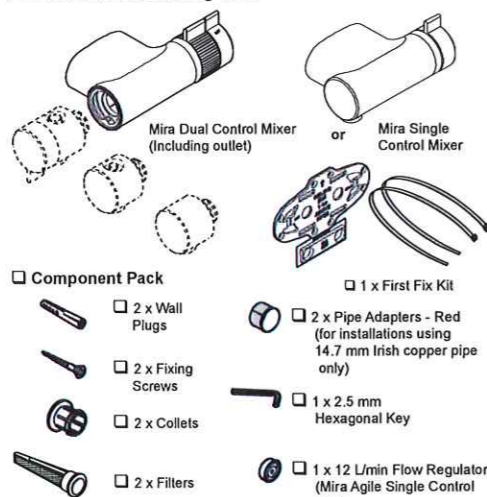

- Documentation**
- 1 x Installation and User Guide
 - 1 x Guarantee Brochure
 - 1 x TMV2 Requirements Manual
 - 1 x Fittings Guide
 - 1 x Accessory Guide (If applicable)

SPECIFICATION

For Type 2 Valves, the supply conditions specified in the TMV2 Requirements Manual take precedence over the operating parameters which follow.

Pressures

- Max Static Pressure: 10 Bar.
- Max Maintained Pressure: 5 Bar.
- Min Maintained Pressure (Gravity System): 0.1 Bar (0.5 Bar for models with Eco Showerhead). (0.1 bar = 1 Metre head from cold tank base to showerhead outlet).
- Note! For gravity fed or other low pressure systems (0.5 bar or below) do not fit the outlet flow regulator (where applicable).
- For optimum performance supplies should be nominally equal.

Temperatures

- Factory Pre-set (Blend) Shower: 41°C.
- Optimum Thermostatic Control Range: 35°C to 43°C (achieved with supplies of 15°C cold, 65°C hot and nominally equal pressures).
- Recommended Hot Supply: 60°C to 65°C Note! The mixing valve can operate at higher temperatures for short periods without damage, however this could detrimentally affect thermostatic performance. For safety and performance reasons it is recommended that the maximum hot water temperature is limited to 65°C.
- Cold Water Range: up to 25°C.
- Minimum Recommended Differential between Hot Supply and Outlet Temperature: 12°C.

Thermostatic Shut-down

- For safety and comfort the thermostat will shut off the mixing valve within 2 Seconds if either supply fails (achieved only if the blend temperature has a minimum differential of 12°C from either supply temperature).

Connections

- Inlets: 15 mm Copper pipe to push fit connector
- Outlet: ½" BSP Flat Face
- Standard connections are:
 - hot - left, cold - right
 - outlet - left

WARNING! This product does not allow for reversed inlets and will deliver dangerously unstable temperatures if fitted incorrectly.

INSTALLATION

Suitable Plumbing Systems

Gravity Fed:

The thermostatic mixer must be fed from a cold water cistern (usually fitted in the loft space) and a hot water cylinder (usually fitted in the airing cupboard) providing nominally equal pressures. Note: It is recommended to remove the 12 L/min flow regulator on low pressure systems, see Fittings Installation and User Guide.

Mains Pressurised Instantaneous Hot Water System (Combination Boiler):

The thermostatic mixer can be installed with systems of this type with balanced pressures. (Recommended Minimum Maintained Pressure: 1.0 Bar).

Note! On combination boiler systems we recommend that the thermostatic mixer is operated in the maximum flow position in order to achieve the minimum flow rate required to ignite and run the boiler.

Unvented Mains Pressure System:

The thermostatic mixer can be installed with an unvented, stored hot water system.

Pumped System:

The thermostatic mixer can be installed with an inlet pump (twin impeller). The pump must be installed in a suitable location and in accordance with its instructions.

General

Installation must be carried out in accordance with these instructions, and must be conducted by designated, qualified and competent personnel.

The installation must comply with the "Water Supply Regulations 1999 (Water Fittings)" or any particular regulations and practices, specified by the local water company or water undertakers.

Note! Make sure that all site requirements correspond to the information given in section: 'SPECIFICATIONS'. For Type 2 Valves see also supply conditions in the TMV2 Requirements Manual.

- The Mixer must not be installed in an area where it may freeze.
- Provision must be made to prevent water ingress back into the water structure.

- Isolating valves must be installed close to the mixer for ease of maintenance.
- Pipework must be rigidly supported and avoid any strain on the connections.
- Decide on a suitable position for the mixer. The position of the mixer and the shower fittings must provide a minimum gap of 25 mm between the spill-over level of the shower tray/bath and the handset (refer to illustration). This is to prevent back-siphonage.

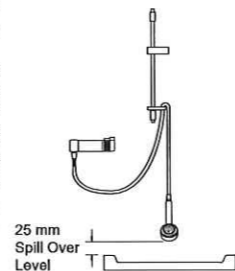

INSTALLATION PROCEDURE

Determine your wall type, Panelled / Partition or Solid Wall. Remove the retaining screw and separate the Mixer Valve from the Backplate.

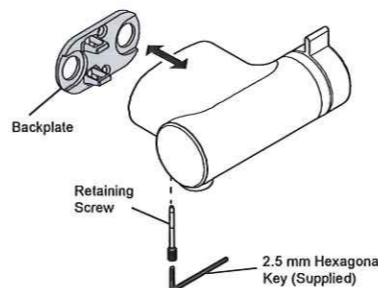

Important! If using 14.7 mm copper pipe in Ireland use the red coloured pipe adapters (supplied) to prevent leaks, see section 13.1.

Installation to a Panelled / Partition Wall

Important! The valve should be securely fixed to a timber noggin or similar arrangement.

- Determine the desired position of the mixer valve. If the mixer valve is to be used in an integrated or diverter configuration the riser rail should be the centerpoint of the installation, therefore the valve should be mounted offset to the right of the riser rail.

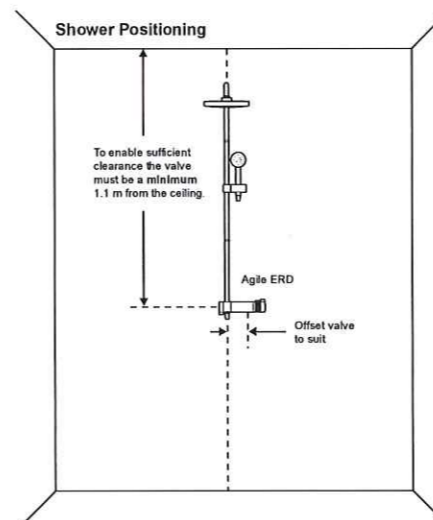

- Install and secure the supply pipework. At this stage the pipework should extend a minimum of 50 mm from the finished wall surface.

Note! Ensure that the pipework protruding from the wall is level and perpendicular. Plastic piping must not be used to connect the valve to the supply pipework.

- Separate the Pipe Spacer from the Tile Guide. The pipe spacer is provided as a useful aid to securing and levelling pipework.

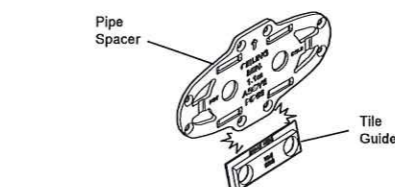

- Important! The mixer valve will not be level if the supply pipe stubs exiting the wall are not level, use a spirit level on the flat surface of the pipe spacer to confirm that it is level before securing the spacer to the noggin.

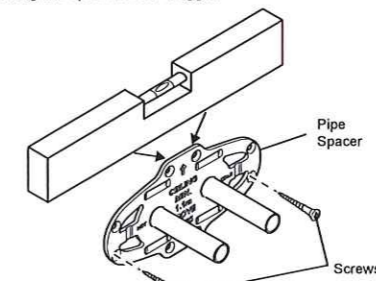

- Screw the pipe spacer to the noggin, using a minimum of 2 screws. If the pipework is not rigidly secured use the cable ties supplied. Ensure it will not interfere with the finished plasterboard.

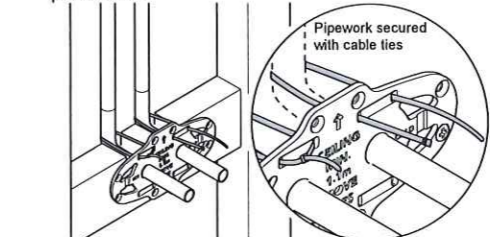

Important! Failure to secure the pipework may result in the pipework pushing back into the wall when fitting the mixer valve.

- Fix the plasterboard / panelling to the wall.
- Fit the Tile Guide over the pipe stubs to assist with the correct spacing for the pipework. Note! Make sure the tile guide is fitted the correct way, Tile Side indicator facing out. Alternately cut 2 16 mm holes 50 mm apart
- Tile accurately up to the inner edge of the tile guide and finish the wall.

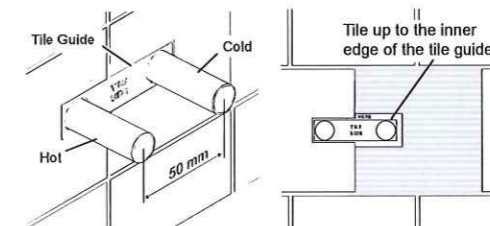

- Using a pipe slice, trim the protruding pipework to 24 - 29 mm. DO NOT use a hacksaw as the sharp edges may damage the seals in the mixer valve. Note! De-burr the pipework if necessary.

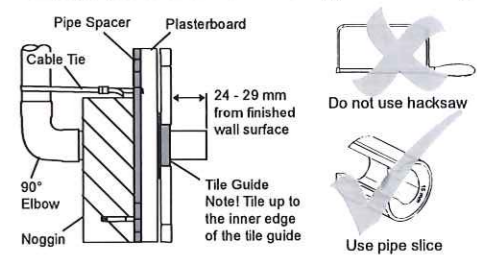

- Slide the Backplate over the pipework, mark the position of the screw holes. Note! Ensure the backplate is fitted the correct way, with the hook to the left.

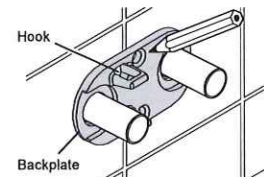

- Drill suitable holes and screw the backplate securely through the wall and into the noggin.
- It is essential at this point that the supply pipework is thoroughly flushed. Caution! Failure to do so may result in product malfunction and will not be covered by the guarantee.
- Slide the Collets onto the pipework, making sure they are pushed firmly against the backplate, then push the Filters into the supply pipes. DO NOT force the filters into the pipework, de-burr the pipework if necessary.

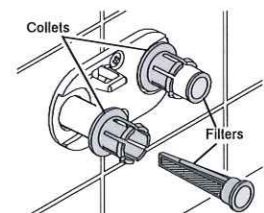

- 13.1 Only for installations using 14.7 mm Irish copper pipe! With the ridged section facing out from the wall push the adapters over the collets. Note! DO NOT use the adapters if using 15 mm copper pipe

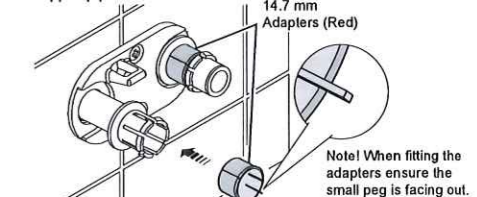

- Push the Mixer Valve firmly onto the backplate. Insert the retaining screw into the Mixer Valve and tighten with the 2.5 mm hexagonal key (supplied).

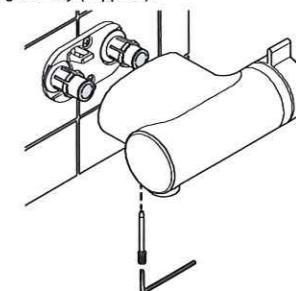

- Turn on the water supplies and check for leaks.
- The installation of the Mixer Valve to a panelled / partition wall is now complete.